

Front view
Scale: 1:1

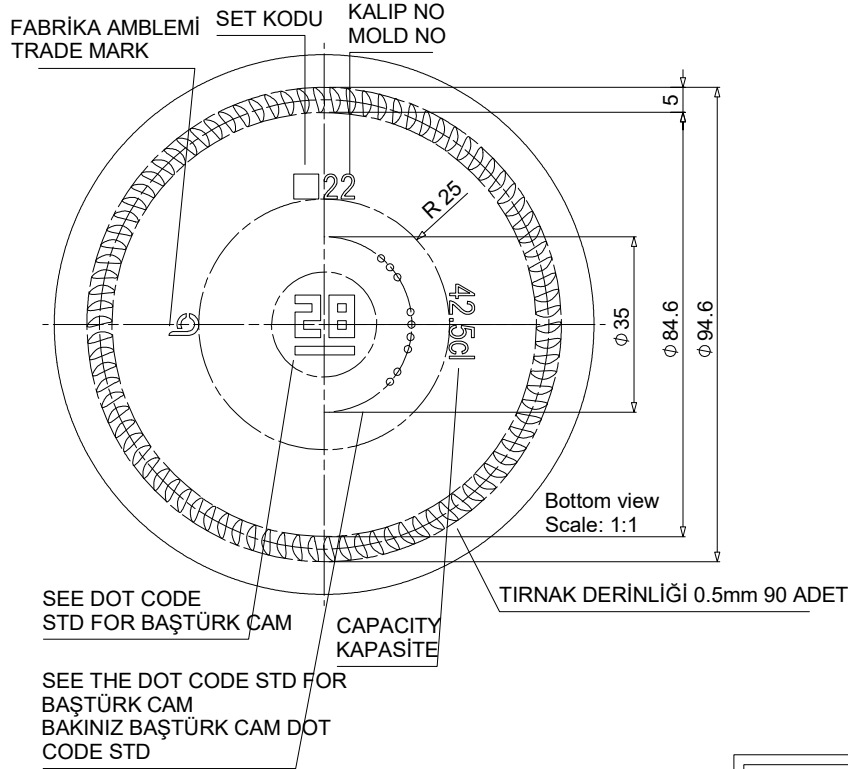
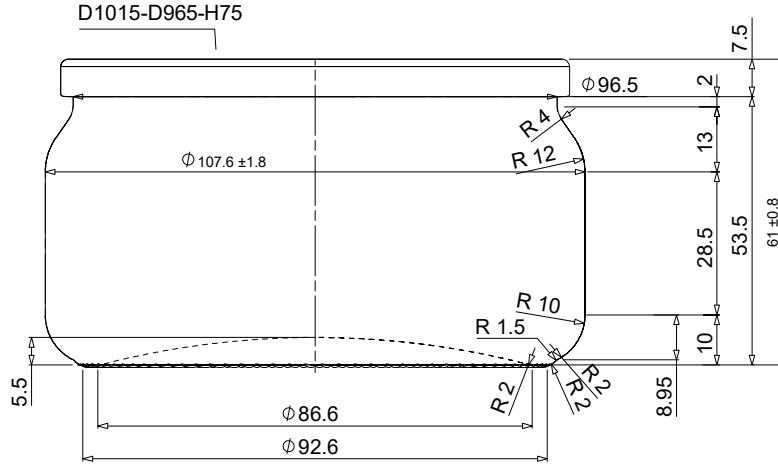

KALIP İŞLERİ ŞEFLİĞİ
TARAFINDAN YAPILMIŞTIR.
(18/05/2022)

b BAŞTÜRK CAM
SANAYİ VE TİCARET A.Ş.

R1	-	-	-	-
REV	ACIKLAMA REMARK	TARİH DATE	CİZEN MADE BY	KONTROL CHECKED BY
DEĞİŞİKLİKLER / REVISIONS				
CİZEN DRAWN BY	-	KAFA STD FINISH	D1015-D965-H75	
KONTROL CHECKED BY	-	DOLUM HACMI FILLING CAP (cc)	-	SİLME HACMI BRIMFULL CAP (cc) 425 ± 13
ONAYLAYAN CONFIRMED BY	-	AGIRLIK WEIGHT (gr)	~	C K (TEORİK) W T (THEORET) (mm) ~
TARİH DATE	18.05.2022	RENK COLOR	FLINT	DENGE ACISI E. ANGLE (°) ~
ÖLÇEK SCALE	-	425 CC SAKLAMA KABI		
Bu tasarım BASTURK CAM SANAYİ tarafından gerçekleştirilmiş olup bütün hakları müşteriye devredilinceye kadar şirketimize aittir. This design has been realized by BASTURK GLASS INDUSTRY and all rights belong to our company until the customer is transferred.		REFERANS REFERENCE	URUN NO PRODUCT NO	GEÇİCİ KOD TEMP CODE
		-	R42501Z1R0	-